

ratio of their diameters, if each is to have the same tension, is equal to

- (a) $Y_{\text{copper}}/Y_{\text{iron}}$ (b) $\sqrt{\frac{Y_{\text{iron}}}{Y_{\text{copper}}}}$ (c) $\frac{Y_{\text{iron}}^2}{Y_{\text{copper}}^2}$ (d) $\frac{Y_{\text{iron}}}{Y_{\text{copper}}}$

Q6. A mild steel wire of length $2l$ and cross-sectional area A is stretched, well within elastic limit, horizontally between two pillars (Figure 1). A mass m is suspended from the midpoint of the wire. Strain in the wire is

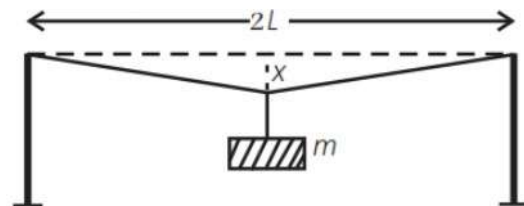

- (a) $\frac{x^2}{2L^2}$ (b) $\frac{x}{L}$ (c) $\frac{x^2}{L}$ (d) $\frac{x^2}{2L}$

Q7. A rectangular frame is to be suspended symmetrically by two strings of equal length on two supports (Figure 2) It can be done in one of the following three ways; The tension in the strings will be

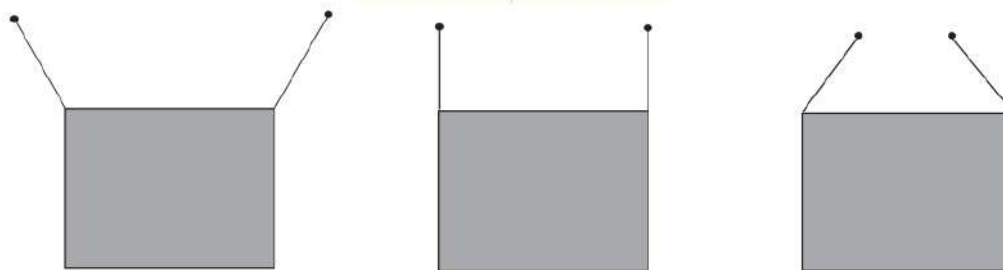

- (a) (b) (c)

- (a) the same in all cases (b) least in (a).
(c) least in (b). (d) least in (c).

Q8. Consider two cylindrical rods of identical dimensions, one of rubber and the other of the steel. Both the rods are fixed rigidly at one end to the roof. A mass M is attached to each of the free ends at the center of the rods.

- (a) Both the rods will elongate but there shall be no perceptible change in

shape.

(b) The steel rod will elongate and change shape but the rubber rod will only elongate.

(c) The steel rod will elongate without any perceptible change in shape, but the rubber rod will elongate and the shape of the bottom edge will change to an ellipse.

(d) The steel rod will elongate, without any perceptible change in shape, but the rubber rod will elongate with the shape of the bottom edge tapered to a tip of the centre.

Multi Choice Questions type II (More than one options are correct)

Q9. The stress - strain graphs for two materials are shown in figure 3 (assume same scale).

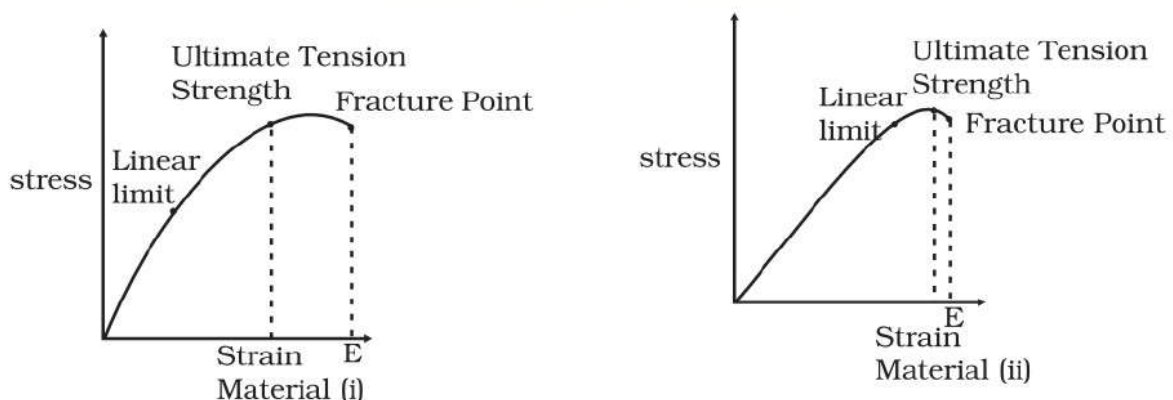

(a) Material (ii) is more elastic than material (i) and hence material (ii) is more brittle.

(b) Material (i) and (ii) have the same elasticity and the same brittleness.

- (c) Material (ii) is elastic over a larger region of strain as compared to (i).
 (d) Material (ii) is more brittle than material (i).

Q10. A wire is suspended from the ceiling and stretched under the action of a weight F suspended from its other end. The force exerted by the ceiling on its equal and opposite to the weight.

- (a) Tensile stress at any cross section a of the wire is F/A .
 (b) Tensile stress at any cross section is zero.
 (c) Tensile stress at any cross section A of the wire is F .

Q11. A rod of length l and negligible mass is suspended at its two ends by two wires of steel (wire A) and aluminium (wire B) of equal lengths (Figure 4). The cross sectional areas of wires A and B are 1.0 mm^2 and 2.0 mm^2 , respectively.

$$(Y_{\text{Al}} = 70 \times 10^9 \text{ Nm}^{-2} \text{ and } Y_{\text{steel}} = 200 \times 10^9 \text{ Nm}^{-2})$$

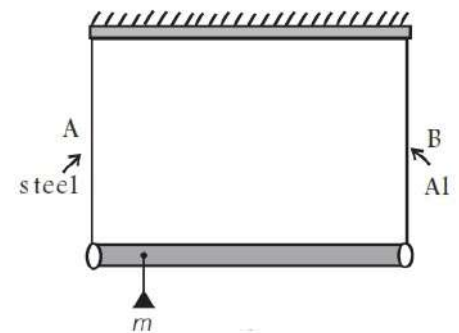

- (a) Mass m should be suspended close to wire A to have equal stresses both the wires.
 (b) Mass m should be suspended close to B to have equal stresses in both the wires.
 (c) Mass should be suspended at the middle of the wires to have equal stresses in both the wires.

(d) Mass m should be suspended close to wire A to have equal strain in both wires.

Q12. For an liquid

- (a) the bulk modulus is infinite.
- (b) the bulk modulus is zero.
- (c) the shear modulus is infinite.
- (d) the shear modulus is zero.

Q13. A copper and a steel wire of the same diameter are connected end. A deforming force F is applied to this composite wire which causes a total elongation of 1cm. The two wires will have

- (a) the same stress
- (b) the different stress
- (c) the same strain
- (d) different strain

Very Short Answers VSA

Q14. The young's modulus for steel is much more than that for rubber. For the same longitudinal strain, which one will have greater tensile stress?

Q15. Is stress a vector quantity?

Q16. Identical springs of steel and copper are equally stretched. On which, more work will have to be done?

Q17. What is the Young's modulus for a perfect rigid body?

Q18. What is the Bulk modulus for a perfect rigid body?

Short Answers Questions SA

- Q19. A wire of length L and radius r is clamped rigidly at one end. When the other end of the wire is pulled by a force f , its length increases by l . Another wire of the same material of length $2L$ and radius $2r$, is pulled by a force $2f$. Find the increase in length of this wire.
- Q20. A steel rod ($Y=2.0 \times 10^{11} \text{Nm}^{-2}$; and $\alpha = 10^{-5} \text{C}^{-1}$) of length 1m and area of cross-section 1cm^2 is heated from 0° and 200°C , without being allowed to extend and bend. What is the tension produced in the rod?
- Q21. To what depth must a rubber ball be taken in deep sea so that its volume is decreased by 0.1% . (The bulk modulus of rubber is $9.8 \times 10^8 \text{Nm}^{-2}$; and the density of sea water is 10^3kg m^{-3} .)
- Q22. A truck is pulling a car out of a ditch by means of a steel cable that is 9.1m long and has a radius of 5mm . When the car just begins to move, the tension in the cable is 800N . How much has the cable stretched? (Young's modulus for steel is $2 \times 10^{11} \text{Nm}^{-2}$.)
- Q23. Two identical solids balls, one of the ivory and the other of wet-clay, are dropped from the same height on the floor. Which one will rise to a greater height after striking the floor and why?

Long Answers Questions L A

Q24. Consider a long steel bar under a tensile stress due to forces F acting at the edges along the length of the bar (Figure 5) Consider a plane making an angle θ with the length. What are the tensile and shearing stresses on this plane?

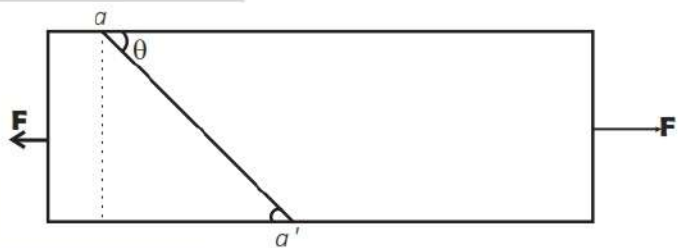

- (a) For what angle is the tensile stress a maximum ?
 (b) For what angle is the shearing stress a maximum?

Q25. (a) A steel wire of mass μ per unit length with a circular cross section has a radius of radius 0.1cm. The wire is of length 10m when measured lying horizontal, and hangs from a hook of a wall. A mass of 25 kg is hung from the free end of the wire. Assuming the wire to be uniform and lateral strains \ll longitudinal strains, find the extension in the length of the wire. The density of steel is 7860 kg m^{-3} (Young's modulus $Y = 2 \times 10^{11} \text{ Nm}^{-2}$).

- (b) if the yield strength of steel is $2.5 \times 10^8 \text{ Nm}^{-2}$, what is the maximum weight that can be hung at the lower end of the wire?

Q26. A steel rod of length $2l$, cross sectional area A and mass M is set rotating in a horizontal plane about an axis is passing through the centre. If Y is the Young's modulus for steel, find the extension in the length of the rod. (Assume the rod is uniform.)

Q27. An equilateral triangle ABC is formed by two Cu rods AB and BC and one Al rod. It is heated in such a way that temperature of each rod increases by ΔT . Find change in the angle ABC . [Coefficient of linear expansion for Cu is α_1 , Coefficient of linear expansion for Al is α_2]

Q28. In nature, the failure of structural members usually result from large torque because of twisting or bending rather than due to tensile or compressive strains. This process of structural breakdown is called buckling and in cases of tall cylindrical structures like trees, the torque is caused by its own weight bending the structure. Thus the vertical through the centre of the gravity does not fall within the base. The elastic torque caused because of this bending about the central axis of the tree is given by $\frac{Y\pi r^4}{4R}$. Y is the Young's modulus, r is the radius of the trunk and R is the radius of curvature of the bent surface along the height of the tree containing the centre of gravity (the neutral surface.) Estimate the critical height of a tree for a given radius of the trunk.

Q29. A stone of mass m is tied to an elastic string of negligible mass and spring constant k . The unstretched length of the string is L and has negligible

mass. The other end of the string is fixed to a nail at a point P . Initially the stone is at the same level as the point P . The stone is dropped vertically from point P .

- (a) Find the distance y from the top when the mass comes to rest for an instant, for the first time.
- (b) What is the maximum velocity attained by the stone in this drop?
- (c) What shall be the nature of the motion after the stone has reached its lowest point?

